

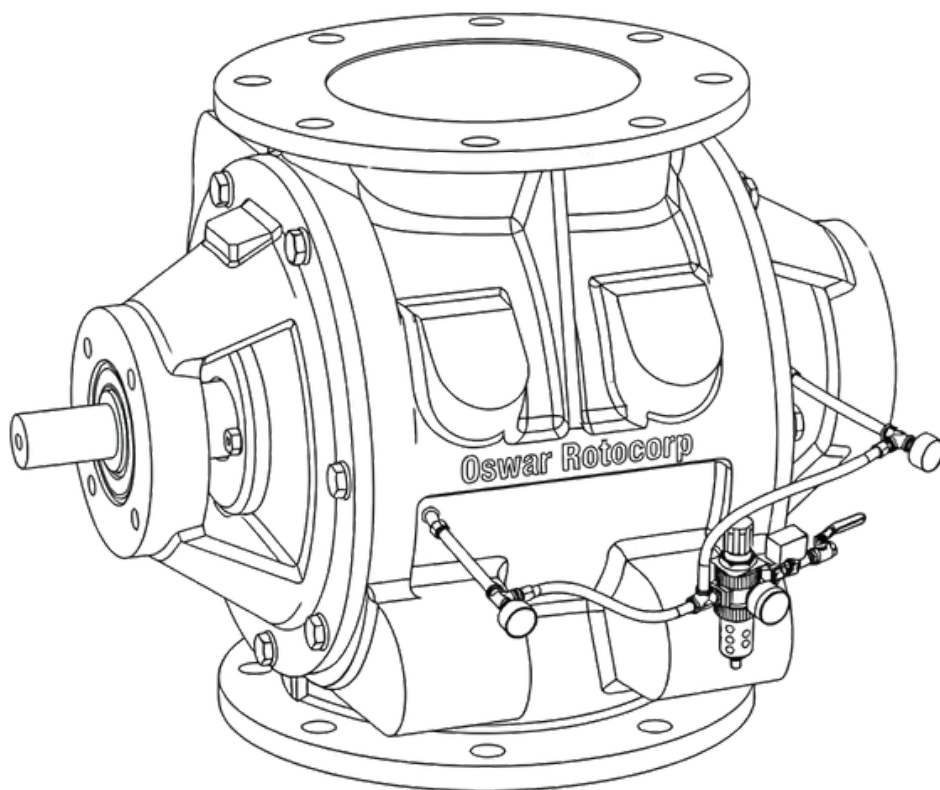

ROTARY VALVE

CONTINUOUS DUTY SERIES



OSWAR
rotocorp



The Rotary Valve X-HD Continuous Duty Series is engineered for applications that demand uninterrupted, high-capacity operation under sustained industrial loads.

Designed as an advanced heavy-duty platform, the X-HD series delivers superior airlock integrity, structural strength, and operational stability in continuous 24/7 process environments. Its reinforced construction and optimized rotor dynamics ensure consistent volumetric control even under fluctuating pressure and material conditions.

ADVANTAGES

ENGINEERED FOR
24/7 OPERATION

REINFORCED
STRUCTURAL
PLATFORM

STABLE
PERFORMANCE
UNDER LOAD
VARIATIONS

REDUCED
MAINTENANCE &
EXTENDED
SERVICE LIFE

BUILT FOR ENDURANCE & OPERATIONAL STABILITY

The Rotary Valve X-HD Series is manufactured with heavy-section CNC-machined housings and high-strength rotor assemblies designed to withstand continuous operational stress. Optimized rotor clearances maintain consistent volumetric efficiency while accommodating thermal and mechanical load variations. Advanced sealing geometry reduces air leakage and energy loss, preserving airlock performance across pressure differentials.

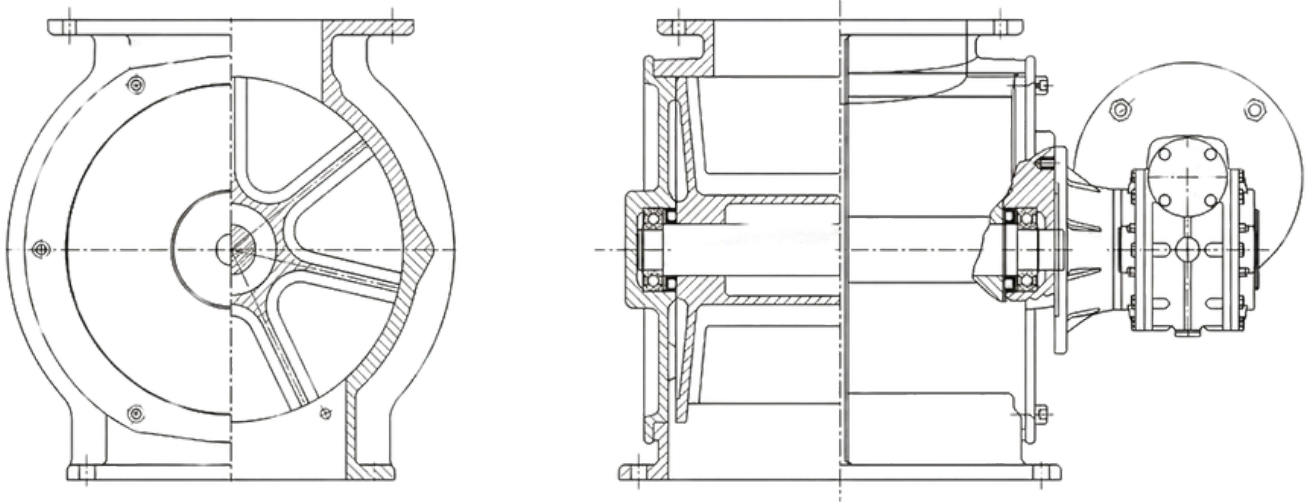

ENGINEERING FEATURES

- Heavy-section precision CNC-machined housing
- High-strength rotor construction
- Controlled clearances for continuous volumetric stability
- Advanced sealing configuration for minimal air leakage
- Heavy-duty bearing and shaft protection systems

CONTINUOUS PROCESS APPLICATIONS

Typical Applications:

- **Kiln & Preheater Discharge Systems**
- **Boiler Ash & Bottom Ash Handling**
- **High-Capacity Silo Discharge**
- **Dense Phase Pneumatic Conveying**
- **Mineral & Ore Processing Lines**

Industries Served:

- **Cement Manufacturing**
- **Power Generation Plants**
- **Mining & Mineral Processing**
- **Steel & Metallurgical Industries**



OSWAR

rotocorp

Corporate Office

Jaipur, Rajasthan India
Nagpur, Maharashtra India

Sales Inquiries

info@oswarrotocorp.com

Helpline

[+44 7917 128505](tel:+447917128505) | [+91 77422 36474](tel:+917742236474)

Copyright © 2026 OSWAR ROTOCORP. All Rights Reserved. OSWAR® is a registered trademark of **OSWAR ROTOCORP**. This brochure makes no offers, representations or warranties (express or implied), and information and data contained in this brochure are for general reference only and may change at any time.